

DESCRIPTION

Low Noise Teslameter with integrated Hall Probe incorporates a high accuracy magnetic field-to-analog-voltage transducer with a high-level, temperature compensated output signal for each of the three components of the measured magnetic flux density, Bx, By and Bz. A digital module is additionally applied to the analog transducer to form the digital Teslameter. Digital Teslameter provides the possibility of automatic data acquisition via a USB serial interface by a host computer. In this way, customers can easily integrate a measurement routine into their measurement system using its programming tools such as Basic, C, C++, Delphi, LabVIEW, etc.

The temperature measurement feature allows user to obtain current temperature values while monitoring the magnetic field.

The transducer consists of two modules:

1. Interchangeable Hall probe and Cable (Module H), and
2. Electronics (Module E).

The Low-Noise Digital Teslameter is a high accuracy temperature-stabilized instrument for the precise measurement of magnetic field.

Each Transducer is calibrated with the individual correction data for the connected probe, so the probe is replaceable.

KEY FEATURES

- **Teslameter with integrated 1-,2-, or 3-axis Hall Probes (Bx, By, Bz)**
- **Measurement of DC & AC magnetic fields**
- **Four selectable magnetic field ranges: 100mT, 500mT, 2T, 20T (20T not calibrated)**
- **Very high magnetic DC resolution: better than 1ppm (@2T range: 1 μ T for planar and 2 μ T for perpendicular components of field)**
(Note: a higher resolution of better than 0.5uT available for a special device version 3MH6-S with a single measurement range of 100mT)
- **DC Accuracy: better than 0.01% (100ppm)**
- **AC Accuracy: see the Table 1. below**
- **Frequency bandwidth: DC – 2.5kHz (-3dB)**
- **Selectable sampling rate up to 7.5ks/sec**
- **High temperature stability: < 20ppm/°C**
- **24-bit A/D Convertor**
- **Auto range, zeroing, hold, MAX/MIN values**
- **Triggers internal and external - single shot and continuous (up to 4kS/sec)**
- **Interchangeable Hall probes with calibration data stored in an integrated EEPROM**
- **TFT LCD graphic display (107 x 71mm) for Bx, By and Bz and the Hall Probe temperature**
- **Numerical, graphical and statistical measurement visualization**
- **Magnetic vector visualization**
- **Measured data recording with selectable sampling rate (0.5s - 60s, i.e. 2.5 - 300 days)**
- **Units in gauss (G), tesla (T)**
- **Embedded computer (GUI on Android)**
- **Remote data acquisition & visualization PC Software runs on Windows 10/7/XP (USB)**



Figure 1: **3MH6 Teslameter**

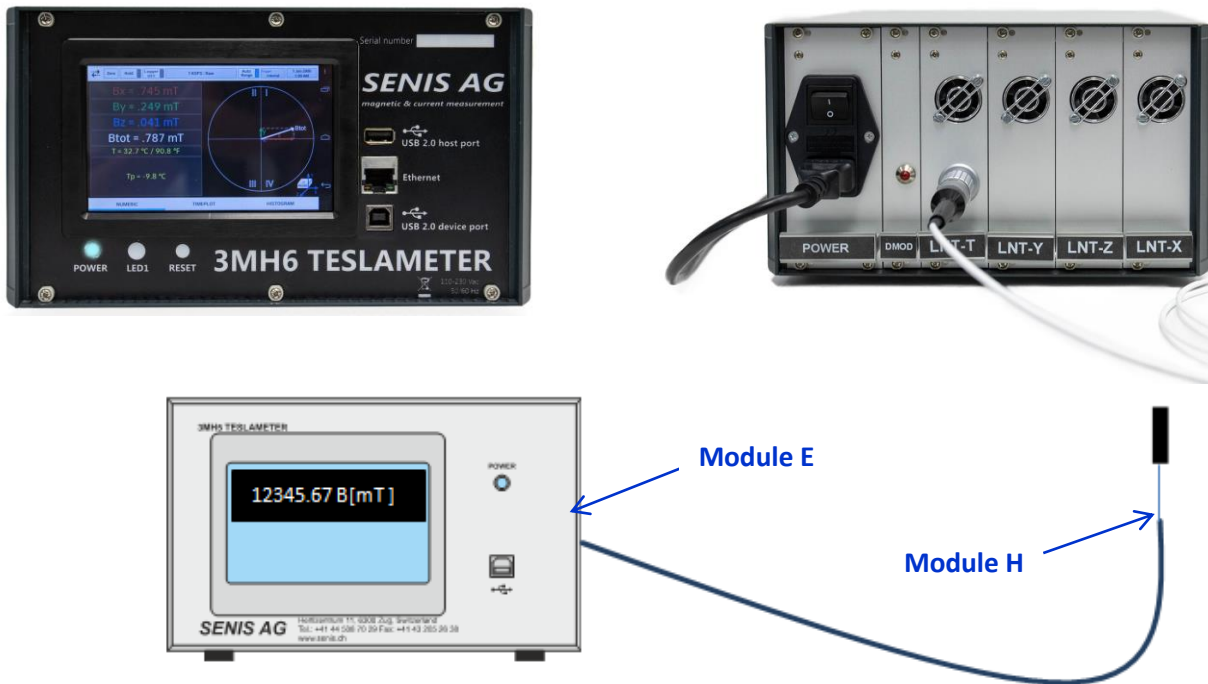

Figure 2: **3MH6 Structure – Module H (Hall Probe of Type C) and Module E (analog and digital electronics)**
Electronic box dimensions (W x H x L): 240 x 140 x 260 mm

HALL PROBE SPECIFICATIONS (Module H):

The Hall Probe of Type C contains a CMOS integrated circuit, three groups of mutually orthogonal Hall elements and a temperature sensor. The integrated Hall elements occupy very small area (100µm x 100µm), which provides very high spatial resolution of the probe.

The output of the Hall Probe are high-level analog voltages proportional to the measured components of a magnetic field and a voltage proportional with the probe temperature for in-electronics compensation of offset and sensitivity temperature drift.

The probe calibration data are stored in an integrated EEPROM allowing probe interchangeability.

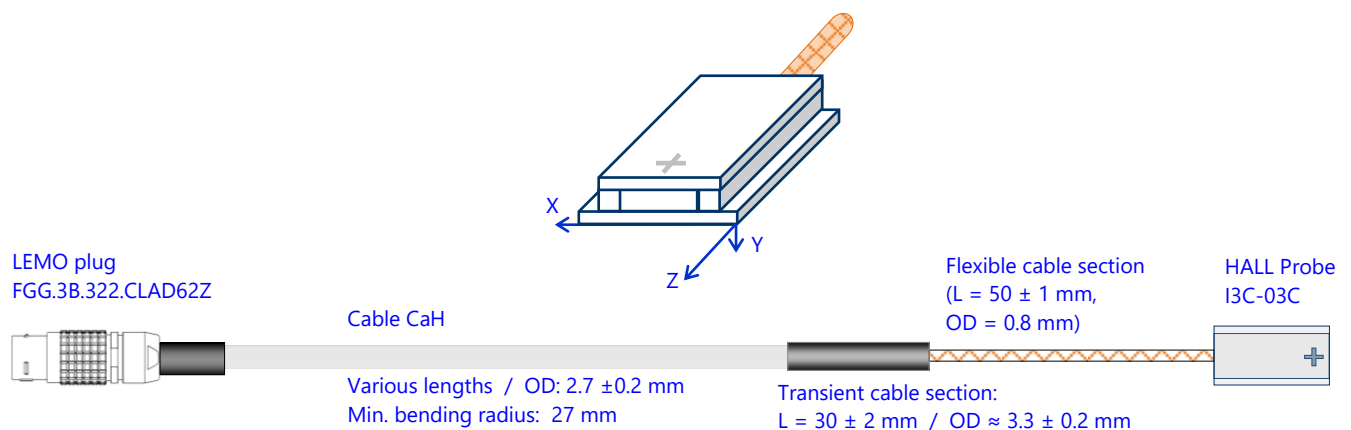

TOP VIEW:

FRONT VIEW:

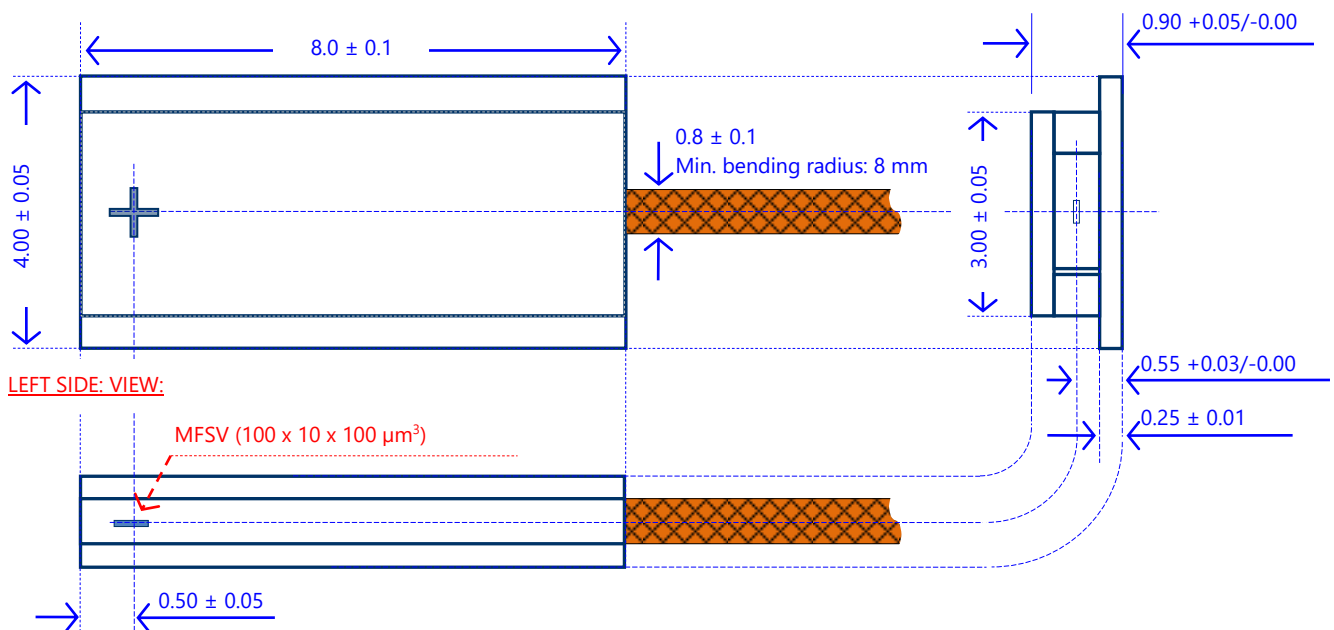

Parameter			
Dimensions	X (mm)	Y (mm)	Z (mm)
Magnetic field sensitive volume (MFSV)	0.10	0.01	0.10
Position of the MFSV centre (Fig. 3 and 4)	2.00 ± 0.05	$-0.55 -0.03/+0.00$	-0.50 ± 0.05
External dimensions of the probe	4.00 ± 0.05	$0.90 +0.05/-0.00$	8.0 ± 0.1
Positioning accuracy			
Angular accuracy of the measurement axes of the Hall probe	$< \pm 2^\circ$ with respect to the reference surface $< \pm 0.2^\circ$ determined during calibration		
Cable properties			
Length:	<ul style="list-style-type: none"> - Standard: 2 m (H-Module notation: I3C-03C02L) - Option: X m (H-Module notation: I3C-03C0XL) Probe-to-Teslameter connector: LEMO plug, FGG.3B.322.CLAD62Z		
Thin cable:	Copper braided flexible cable, OD 0.8 mm		
Conductor:	Silver plated soft copper core, 7 x 44 AWG		
Insulation:	PFA (Perfluoro Alkoxy), diameter 0.30 mm		
Safe cable twisting:	15 x OD Thin (red) cable 10 x OD Thick (white) cable		
Shield:	Silver plated soft copper braid		
Jacket:	PFA (Perfluoroalkoxy)		
Service temperature:	$-196 / +200$ °C		
Linear resistance:	1.4 Ω/m		
Rated voltage:	150 Vac		
RoHS compliance:	Yes		

Figure 3: Module H, Hall Probe of Type C – Dimensions and Parameters

PRELIMINARY MAGNETIC AND ELECTRICAL SPECIFICATIONS:

4 selectable magnetic field measurement ranges:	± 100mT, 500mT, 2T, 20T (20T range is not calibrated)
Total measuring accuracy:	0.005% of measurement range
Magnetic resolution:	2ppm (24bit A/D conversion)
Frequency bandwidth:	DC – 2.5kHz (-3dB)
Sampling rate (selectable):	up to 7.5kSamples/sec
Selectable averaging time:	100ms - 133µs
Temperature stability:	20ppm/°C
External trigger:	single shot / continuous; up to 4'000 Samples/sec
Measured data recording:	data acquisition every 0.5sec – 60sec (up to 300 days)

FREQ. BANDWIDTH vs. RESOLUTION:

Data rate [sp/s]	10	100	500	2000	7500
Averaging time [ms]	100	10	2	0.5	0.133
Resolution [µT rms]	0.8	1	2	3	5
f (-10ppm) [Hz]	0.03	0.27	1.4	<u>5</u>	<u>10</u>
f (-100ppm) [Hz]	0.08	0.8	4	<u>18</u>	<u>30</u>
f (-0.1%) [Hz]	0.25	2.5	12.5	50	<u>90</u>
f (-1%) [Hz]	0.78	7.8	39	155	<u>300</u>
fc (-3dB) [Hz]	4.4	44	220	880	<u>2500</u>

Conditions:

- Range: ±2T
- Probe cable length: 2m
- Internal Sampling rate: 30ks/s
- Bandwidth: DC to fc(-x), where f (-x) is the B signal frequency at which the measurement error with respect to DC reaches x.

Underlined are the frequency values that are limited by the analog LP filter of the 3MH6 Teslameter.

Table 1. The table shows the combinations of the magnetic signal frequencies and measurement resolutions that are achievable with the 3MH6.

Notations:

Data rate [sp/s], samples per second: is the rate with which the measurement data appear at the teslameter's digital output. In the teslameter specifications it is called the **"Selectable sampling rate"** and it goes up to 7.5ks/sec. This is one of the main parameters that a user should select on the teslameter's front panel. Once a data rate is chosen, this will define the Data **Averaging time [ms]** as the inverse of the data rate. For example, if the data rate of 10 samples per second is chosen, then the teslameter will spend 100 milliseconds with averaging the raw measurement results.

Resolution [µT rms]: The minimal measured value - for example, if the data rate of 100 samples per second is chosen, then the measurement resolution will be about 1 µT(rms).

f(-"x"): These are the frequencies at which the measured signal attenuation with respect to the DC value reach a given value (this, due to various low-pass filtering effects within the Teslameter). For instance, the line "f(-10ppm)" shows that if the the data rate is 7.5 ks/s, at the signal frequency of 10 Hz, the measured B-field amplitude will appear 10ppm lower than its true value. At the highest data rate, the signal attenuation reaches 3dB at the frequency of about 2.5 kHz, which is the cutoff frequency of the built-in anti-aliasing filter.

GRAPHICAL USER INTERFACE:



Figure 4: Visualization Modes (Numeric, Plot, Histogram) and Setting possibilities; External/Internal Triggers; Data Recording; Auto range; Zeroing; Min/Max; Hold reading;

OTHER VERSIONS OF 3MH6 SERIES:

3MH6-S – Special Edition:

Very High Resolution of better than 0.5uT for a special device version with a single measurement range of 100mT