

Datasheet:**Hall probe type C for SENIS 3MH6-E, 3MH6 & 3MH4 Digital Teslameters and I3D low-noise analog magnetic field transducers****DESCRIPTION:**

The Hall probe type C for the SENIS' high-performances digital teslameters 3MH6-E, 3MH6 and 3MH4, and I3D low-noise analog magnetic field transducers is a miniature 3-axis Hall-probe system that gives simultaneous analogue voltage outputs for all three components (Bx, By, Bz) of the measured magnetic flux density and for the probe temperature.



Figure 1: Hall probe type C

The probe contains a high-resolution integrated CMOS Hall element, which incorporates three groups of the Hall elements and a temperature sensor.

The integrated Hall elements occupy very small area ($100 \times 100 \mu\text{m}^2$), which provides very high spatial resolution of the probe.

The sensor chip is embedded in the probe package and connected to the CaH cable, which improves its mechanical and electrical robustness.

The chip is glued onto a reference ceramic plate suitable for an appropriate alignment of the probe.

Key features of the C Hall probe:

- Hall probe type C is a very robust Hall Probe suitable for the vacuum environments. The chip is glued onto a reference ceramic plate suitable for an appropriate fixing of the probe
- Integrated CMOS 3-axis (Bx, By, Bz) Hall Probe, of which one, two, or three channels are used
- Very low noise and offset fluctuations
- Very high spatial resolution: By: $30 \times 5 \times 30 \mu\text{m}^3$; Bx & Bz: $100 \times 10 \times 100 \mu\text{m}^3$
- Very high linearity
- High angular accuracy of the measurement axes: mutual orthogonality between the three measurement axes is $< \pm 1^\circ$, determined with accuracy better than 0.1° by the application of an improved method
- Virtually no planar Hall Effect
- Negligible inductive loops on the Probe
- Integrated temperature sensor on the probe for temperature compensation

H-Module I3C-03C0XL (3-axis Hall Probe & Cable) - Mechanical specifications:

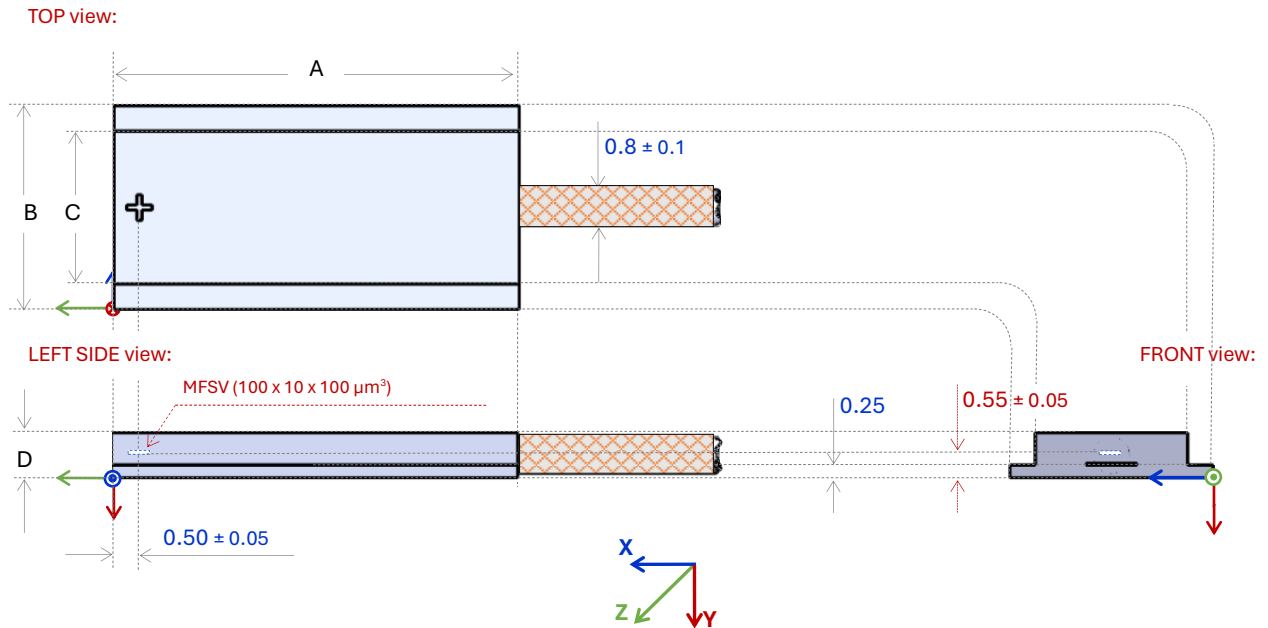

Hall Probe Connector:

- 3MH6-E/3MH4: LEMO FGG.3B.322.CLAD62Z
- I3D transducers: Switchcraft 18P MALE CORD

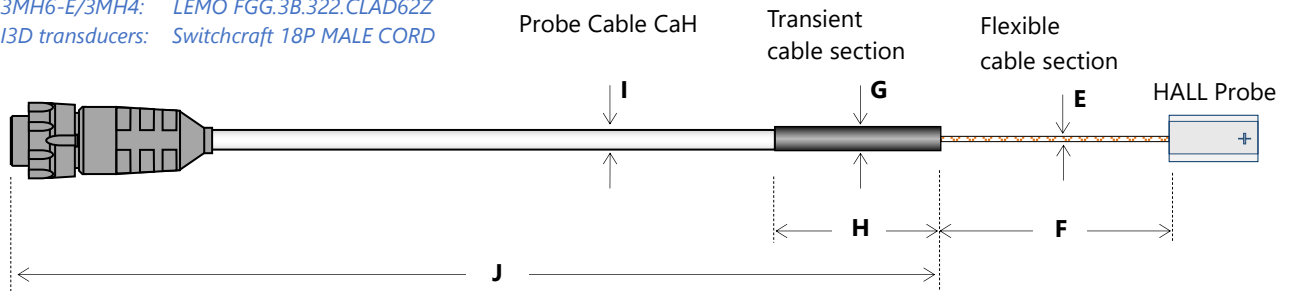

Part	Dimension (mm)
A	8.00 ± 0.05
B	4.00 ± 0.05
C	3.00 ± 0.05
D	0.90 +0.05/-0.00
E	∅ 0.8 ± 0.1
F	50 ± 1
G	∅ 3.0 ± 0.2
H	30 ± 2
I	∅ 2.7 ± 0.1
J	Standard lengths of the probe Cable are: 2, 5 and 10 m. Different lengths are available on a demand.

Figure 2: Dimensions of the H-module I3C-03C0XL (where X denotes length of the probe cable in meters (m))

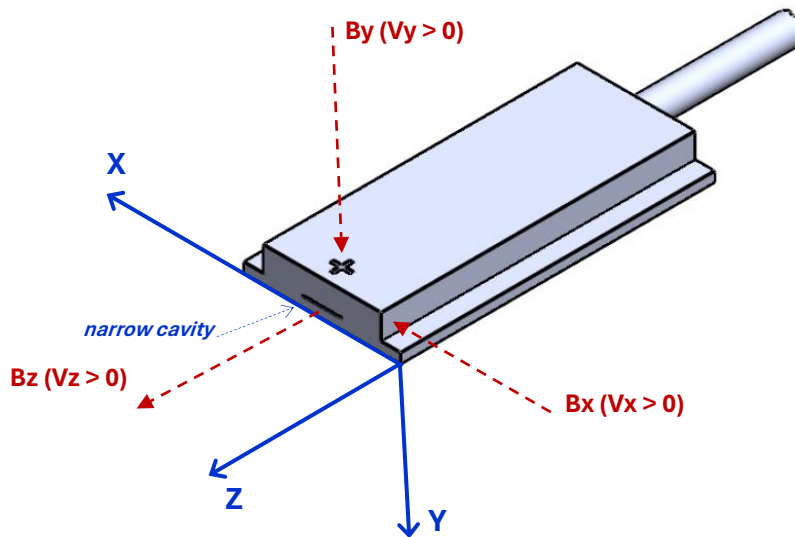

Figure 3: Reference Cartesian coordinate system (X, Y, Z) of the 3-axis Hall probe type C

Parameter			
Dimensions	X (mm)	Y (mm)	Z (mm)
Magnetic field sensitive volume (MFSV)	0.10	0.01	0.10
Position of the MFSV centre (Fig. 2 and 3)	1.00 ± 0.05	$-0.55 -0.05/+0.00$	-0.50 ± 0.05
External dimensions of the probe	4.00 ± 0.05	$0.90 +0.05/-0.00$	8.00 ± 0.05
Positioning accuracy			
Angular accuracy of the measurement axes	<ul style="list-style-type: none"> $< \pm 1^\circ$ with respect to the reference surface Mutual orthogonality between the meas. axes: $< \pm 1^\circ$ (determined with an accuracy of better than 0.1° by the application of a well-improved measurement method) 		
Cable properties			
Conductor:	Silver plated soft copper core, 7 x 44 AWG		
Insulation:	PFA (Perfluoro Alkoxy), diameter 0.30 mm		
Twisting:	15 x OD		
Shield:	Silver plated soft copper braid		
Jacket:	PFA (Perfluoroalkoxy)		
Service temperature:	$-196 / +200 \text{ }^\circ\text{C}$		
Linear resistance:	$1.4 \text{ } \Omega/\text{m}$		
Rated voltage:	150 Vac		
RoHS compliance:	Yes		

Installation Manual for the Hall probe type C:



NOTE: The C probe is fragile! Please handle it with a special care.

Hall probe type C is made of the two thin ceramic plates and can be easily broken. Therefore, avoid any mechanical contact of the probe tip with other objects! Moreover, avoid the immersion of the probe in any liquid, as well its exposure to moisture and aggressive gasses.

Considering that we deal with a high-precision device of very small dimensions, following precautions should help to avoid damage to the probe during installation and handling, and ensure that the accurate calibration of the device remains preserved:

- Always disconnect powering of the instrument before plugging/unplugging the Hall probe!



- Applied CMOS Hall sensor can be damaged by ESD. We strongly recommend that the probe be handled with appropriate ESD preventive precautions. Failure to observe proper handling and installation procedures can cause damage. ESD damage can range from subtle performance degradation to complete device failure.
- Mounting of the Probe should be carried out by application of very low pressure to its head and the thin red cable.
- Do not apply more force than required to hold the probe in its place. Damage to either the ceramics package of the Hall sensor or thin wiring could destroy the Probe.
- If the probe head is clamped, the user needs to make sure that the environment surface in contact with the reference plane of the probe is flat and covers as much of the probe reference surface as possible.
- Do not apply more force than required to hold the probe in its mounting. Also, do not press the probe just in a single spot. Pressure on the probe should be uniformly distributed over its upper surface.

To relax a stress while mounting or gluing the probe in a groove, it is recommended to press the probe by application of a flat 0.2 - 0.5 mm thick soft polymer or a rubber foil over the upper surface of the probe:

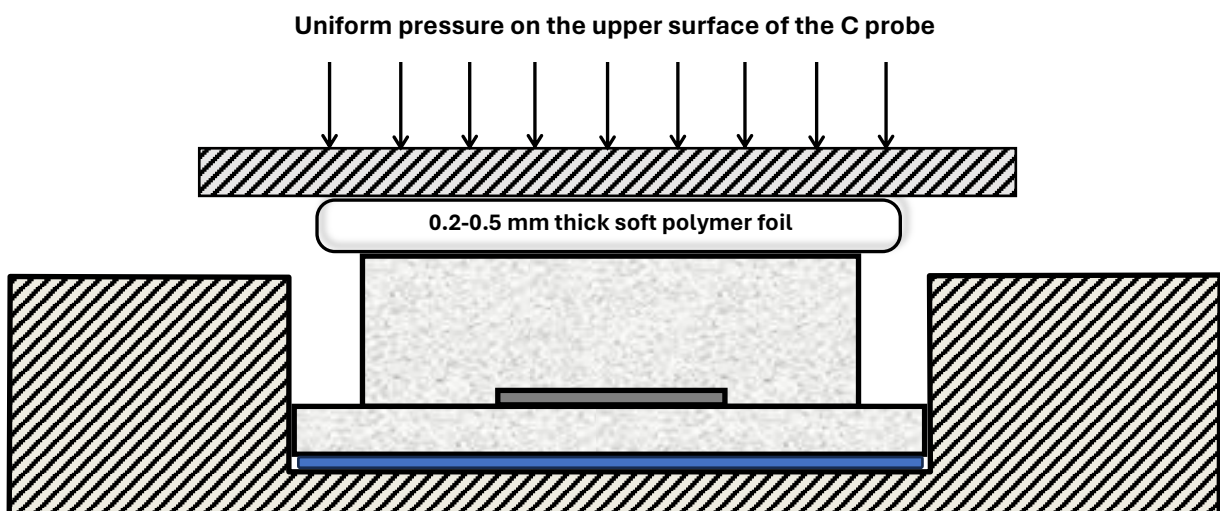

- In order to prevent rupture of the thin probe wiring, the user should fix and secure the probe cable in the proximity of the head. The thin red wire from the probe can be folded only with a special care. Strongly avoid loops or twisting of this section.

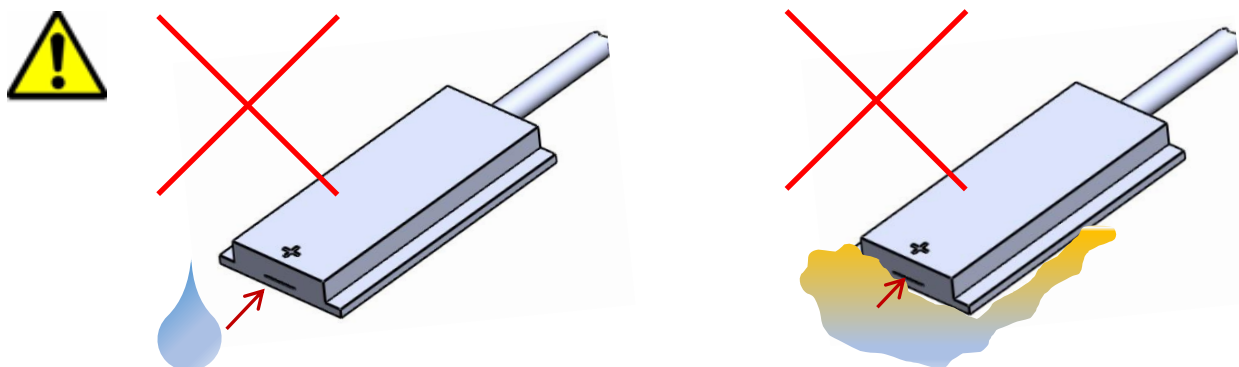
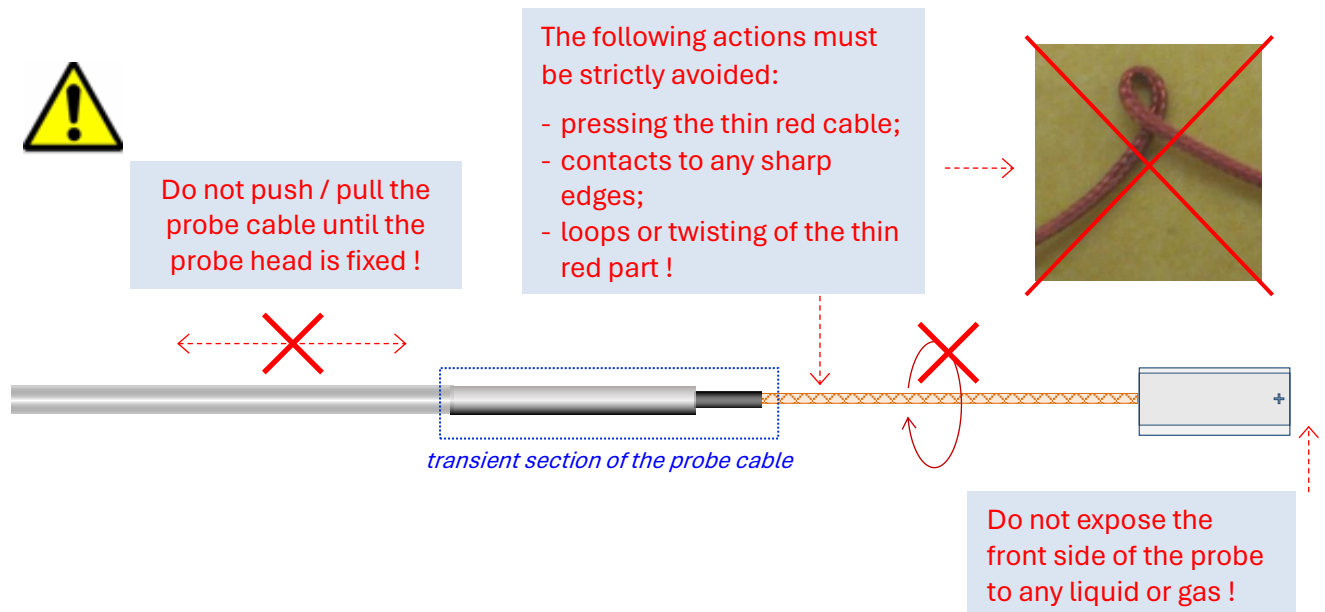

Strongly avoid contact of the FRONT side of the probe (with the cavity) with any liquid or a grain mass (such as a glue). Due to capillary effect, such matter could enter through the cavity into the interior of the probe and destroy or deteriorate the characteristics of the CMOS Hall sensor!

- Do not expose the thin red cable to the external sharp edges.
- Do not expose the probe to moisture and aggressive gasses.
- Avoid immersion of the probe in any liquid.
- Strongly avoid any high pressure, tightening and/or bending of the rigid (non-flexible) **transient section** between the thin (red) and thick (white) probe cables.

- Safe area for bending the thick (white) probe cable is specified on the following drawing:

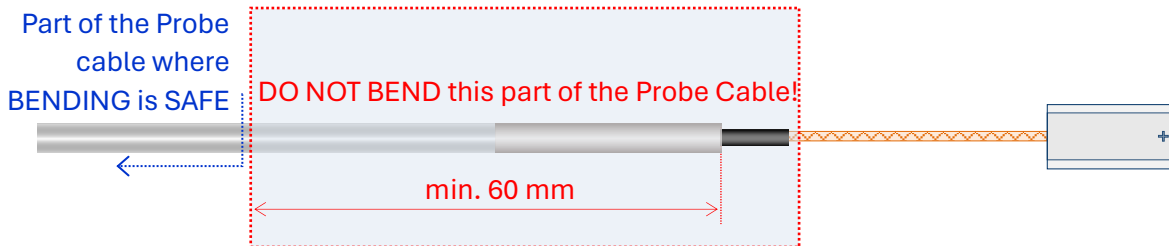

- Keep the cable out of the way of foot traffic. Do not pinch the cable, or drop sharp or heavy objects on it. Severed cable cannot be re-joined without altering the probe performance, and requires factory repair and full re-calibration of the device.
- Example / proposal for a safe fixation of the C probe on a probe holder:

