

Operation Manual

3MH1-E HANDHELD TESLAMETER



1. Table of Contents

2.	Safety precautions:	3
3.	Installation:	4
3.1	<i>SCOPE OF DELIVERY</i>	4
3.2	<i>GETTING STARTED</i>	4
3.3	<i>OPERATIONAL CONDITIONS</i>	5
4.	Introduction	6
5.	Setup	7
5.1	<i>MOUNTING OF THE 3MH1-E HALL PROBE ONTO THE TESLAMETER BODY</i>	7
5.2	<i>CONNECTING THE 3MH1-E HALL PROBE TO THE TESLAMETER BODY OVER PROBE EXTENSION CABLE</i>	7
5.3	<i>FIELD SENSITIVE VOLUME – FSV</i>	7
5.4	<i>DIMENSIONS</i>	9
6.	Calibration of the device.....	10
7.	Operation:.....	11
7.1	<i>STARTING THE DEVICE</i>	11
7.2	<i>LIVE DATA AND DETAILED VIEW OF PARAMETERS</i>	12
7.3	<i>SETTINGS</i>	13
7.4	<i>MEASUREMENT UNITS</i>	13
7.5	<i>MEASUREMENT RANGES</i>	14
7.6	<i>SAMPLE RATE</i>	14
7.7	<i>STATISTIC TIME</i>	14
7.8	<i>ABOUT PAGE</i>	15
7.9	<i>RECORD DATA IN FILE</i>	15
8.	3MH1-Probe:	18
9.	3MH1-Cable:.....	19

The figures shown in this manual are for reference only and may not be an exact representation of the product as well as those specifications subject to change without notice.

The displayed information is believed to be accurate and reliable. However, no responsibility is assumed SENIS AG for its use, nor for any infringements of patents or other rights of third parties that may result from its use.

2. Safety precautions:



If you discover any abnormalities while checking the device, before or during use, stop using the device and inform the manufacturer.



Do not disassemble or modify the device. Repair, disassembly, and modification only by manufacturer approved technicians.



Do not apply undue force to plugs, cables or the sensor probe.



Be aware when using the device (electronics module) in vicinity of a strong magnetic field source since include slightly magnetic parts

3. Installation:

3.1 Scope of Delivery

- SENIS 3MH1-E, Handheld Teslameter (the body of the teslameter)
- SENIS 3MH1-P, Detachable Hall Probe
- SENIS 3MH1-C, Probe Extension Cable (Optional)
- USB-C Cable

All related software and manuals are located at SENIS' website www.senis.swiss in the *Downloads* section.

3.2 Getting started

The nonmagnetic Lithium battery (2Ah) is fixed installed in the enclosure of the device. This battery is classified as "contained in equipment", not just packed with, so it requires a special protection for the device transportation. Battery terminals are short-circuiting protected with the protection electronics installed inside the device. There is one battery per device with a lithium battery label on backside of the device.



To start to use the device please move the switch to the full left position. Then use USB-C cable and connect device to the PC for battery charging. You may use device short time after that.

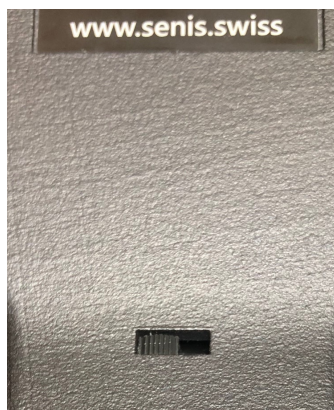

Figure 1: SENIS 3MH1-E Handheld Teslameter, Back side with battery switch in operational position (left side)

3.3 Operational Conditions

This instrument is designed for indoor use only and should not be used outdoors.

NOTE: While the measurement probe is fully non-magnetic, the electronics module is not fully non-magnetic. Although, SENIS has taken the special care when developing the electronics module (e.g., fully nonmagnetic battery, no ferro-magnetic components and switches were used, etc.), there are still some small ferro-magnetic parts inside the electronics enclosure (e.g., the SIM card holder).

!!WARNING!!: Be aware when using the device (electronics module) in vicinity of a strong magnetic field source.

4. Introduction

Thank you for purchasing the SENIS 3MH1-E Handheld Teslameter.

This portable instrument makes measuring magnetic fields easier than ever before. With its fully integrated 3-axis Hall probe, users can measure all three magnetic field components simultaneously at virtually the same point, resulting in a fast, high-resolution measurement of magnetic flux density.

The device features an integrated touchscreen that provides a direct view of the magnetic field strength and user-friendly software that allows for easy changing of the unit of the measured magnetic field, range, and measurement averaging time window.

The built-in software lets users to record data in a CSV file on delivered SD card.

Moreover, the device is powered by an internal rechargeable battery and does not require an external power supply (except for battery charging). Battery charging is realised with USB-C cable and connection to any PC or to appropriate electricity plug.

With its tiny field-sensitive volume of only $100\ \mu\text{m} \times 100\ \mu\text{m} \times 10\ \mu\text{m}$, SENIS Handheld probe can easily measure homogeneous and highly inhomogeneous magnetic fields.

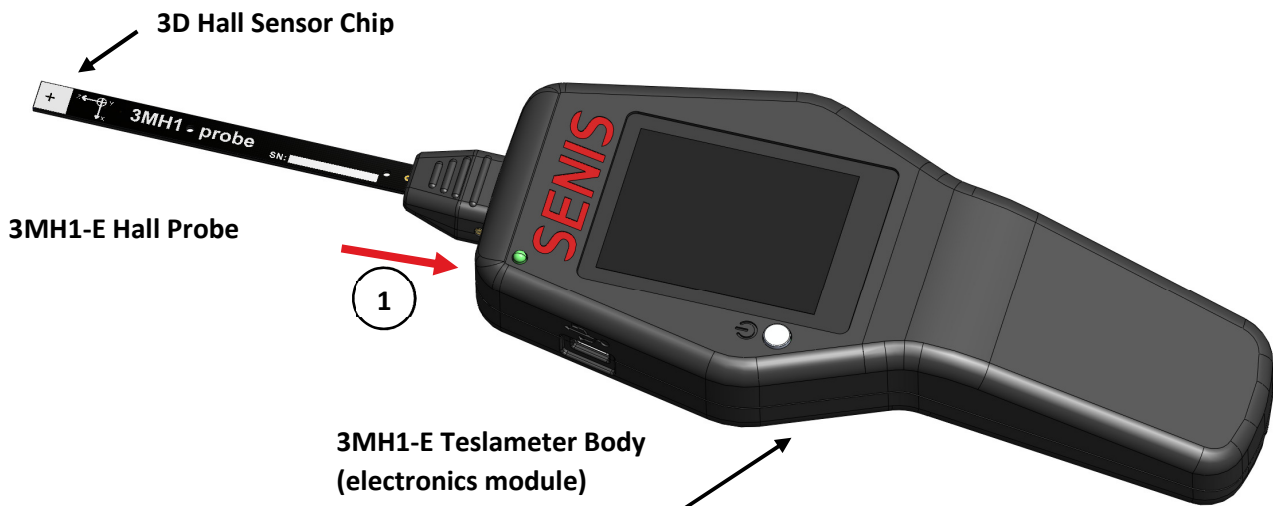

Figure 2: SENIS 3MH1-E Handheld Teslameter, Front side



Figure 3: SENIS 3MH1-E Handheld Teslameter, Back side

5. Setup

The SENIS non-magnetic detachable probe accurately measures all three magnetic field components enabling comprehensive magnetic field analysis. It allows for full interchangeability with any electronic device due to the fact that the probe calibration data are stored in the probe itself (3D Hall sensor registers).

5.1 Mounting of the 3MH1-E Hall Probe onto the Teslameter Body

1. Make sure that 3MH1-E teslameter is turned off before inserting the Hall probe into the socket.
2. Take the 3MH1-E Hall probe with one hand holding it for the connector and positioning the sensor chip face up (at the same side as a display)
3. Insert the probe into the socket on the teslameter body firmly as shown in Fig.1, pos 1

5.2 Connecting the 3MH1-E Hall Probe to the Teslameter Body over Probe Extension Cable

The 3MH1-E Hall probe can also be connected to the teslameter body by means of the supplied probe extension cable. The procedure for connecting Hall probe over the cable is similar as when the Hall probe is connected directly to the teslameter body (Figure 1).



Figure 4: Connection of the Hall probe to the Teslameter body using the extension cable

Figure 5:

5.3 Field Sensitive Volume – FSV

The FSV of the probe denotes the volume within which all three components of the magnetic field are measured. The horizontal and vertical Hall elements are symmetrically arranged around the centre of the FSV, ensuring accurate measurements. The FSV in the probe chip is $100 \times 100 \times 10 \mu\text{m}^3$, enabling precise and local measurements.

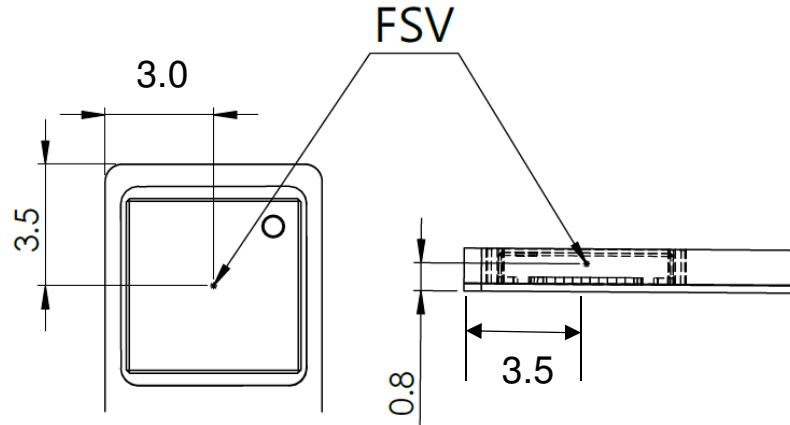

Figure 6: The probe sensor chip FSV center position regarding the edges of the 3MH1-P Hall probe tip – probe top view (left) and side view (right)

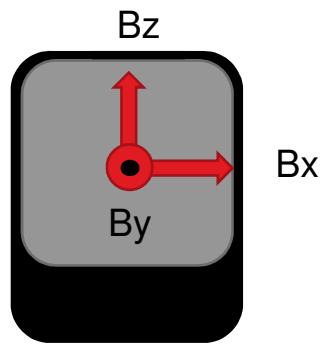

Figure 7: Magnetic field sensitivity axis orientation (probe top view)

5.4 Dimensions

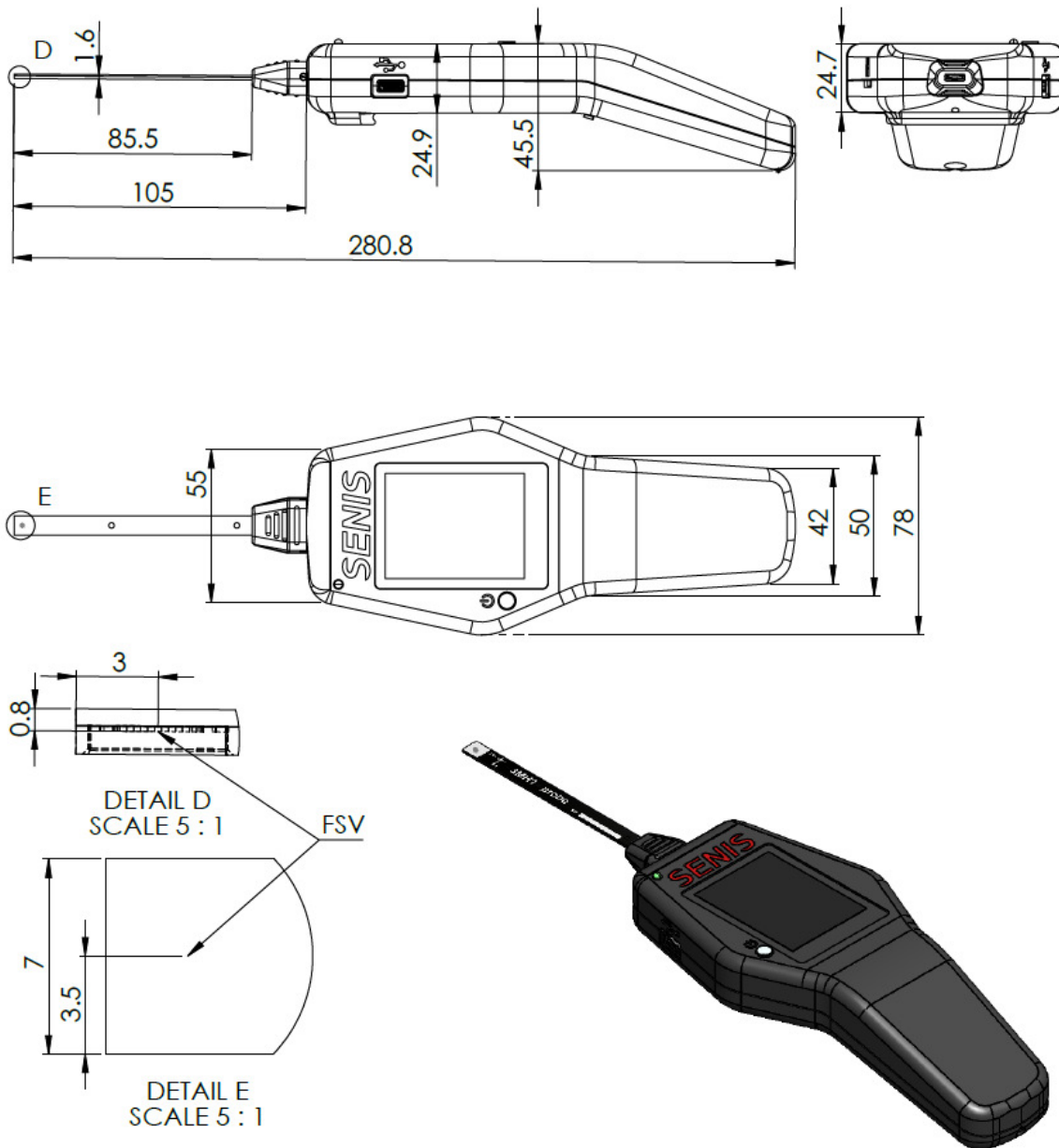

Figure 8: Structure and dimensions of the 3MH1-E Handheld Teslameter and position of the FSV

6. Calibration of the device

The SENIS 3MH1-E handheld Teslameter has a calibrated, fully integrated 3-axis Hall probe.

The probe is calibrated in SENIS's Accredited Calibration Laboratory to ensure accuracy and reliability.

SENIS exclusively provides recalibration services, and we recommend recalibrating the device every 12 months to maintain optimal performance. For probe recalibration, it is sufficient to send to SENIS' Laboratory the probe only (without electronic module).

7. Operation:

7.1 Starting the device

- Use the USB-C cable provided by SENIS to connect the device and charge
- To turn on the device, use the ON/OFF switch located on the left side of the display
- The system is checking itself (settings, calibration files, hardware).
- Within 2s the screen will turn on. Shortly after it, the device is ready for operation.

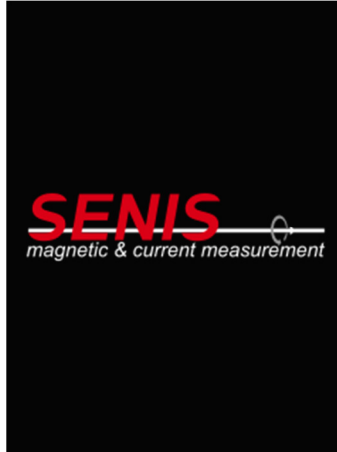

- Once the checks are complete, a splash screen will appear to welcome the user.

For connecting the device to the computer use only USB 3.0 port or higher together with the cable delivered with the device.

After switching-on the device and after the splash screen with SENIS logo has disappeared, the main screen of the SENIS Handheld Teslameter displays several options as showed in next chapters.

The battery status indicator on the top right-hand corner of the screen shows whether the battery is charging or how much battery is remaining during use.

During the battery charging process, a flash icon is displayed over the battery indicator. Once the battery reaches full charge, the flash symbol disappears, and in its place, four vertical bars appear, indicating that the battery is now fully recharged.

Once the device is switched on and after a short time (5 sec) of electronics warming-up phase the the user can start navigating through the main menu options using the arrow icon.

7.2 Live data and detailed view of parameters

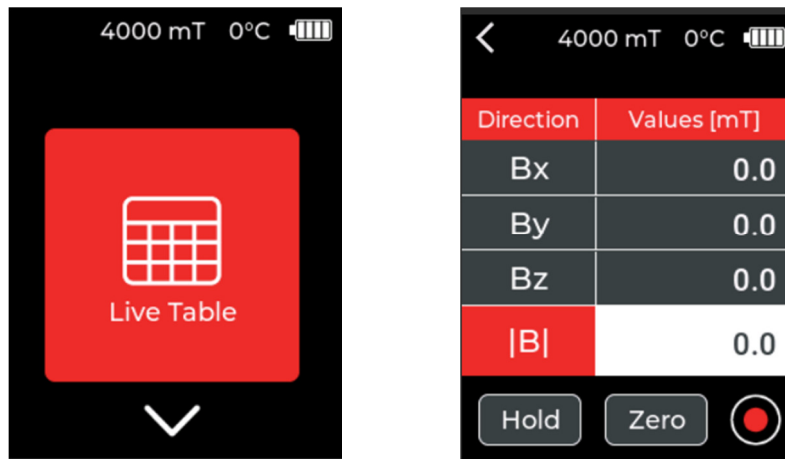

Figure 9: Live table screen

The live table window of the SENIS 3MH1–E Handheld Teslameter presents the measured values of the magnetic field’s Bx, By, and Bz, along with the overall magnitude of the magnetic field (|B|) as well as the battery status, temperature of the magnetic sensor chip in degrees Celsius (top right corner) and the selected magnetic field measurement range (top mid area). Please note that the displayed chip temperature value is not the room temperature (usually higher than room temperature).

The magnetic field measurement unit can easily be changed on the settings page, and the active measurement unit is displayed with the selected measurement range to the left of the temperature value.

Recording button is present in bottom right corner of screen.

The “Zero” function resets current magnetic fields readings to zero value when enabled. It can be used for cancelling the offset using Zero Gauss Chamber. It is possible to zero the offset during measurement - the measured magnetic field values will be zeroed, which can be used to observe relative changes in field strength. When the “Zero” function is disabled, the field readings come back to calibrated values.

The “Hold” function freezes the current readings when enabled. To “unfreeze” the measurements disable the Hold function again.

Users can view the measurement details by clicking on the name in the Bx, By, Bz, or |B| (Btotal) table. This includes the minimum, maximum, root mean square, and average parameter values for the time window selected in the settings menu.

Direction	Values [mT]
Bx	0.0
By	0.0
Bz	0.0
B	0.0

Bx [mT]	-2.7
Min	-4.0
Max	1.7
RMS	1.9
AVG	-1.4

Figure 10: Detailed view of parameter Bx form live data table

7.3 Settings

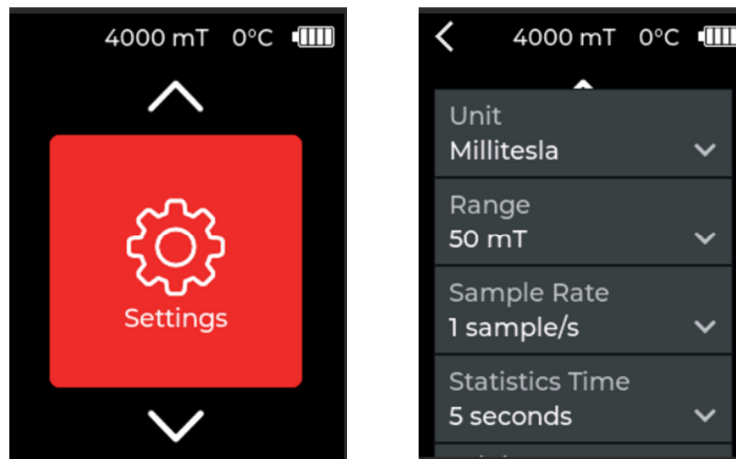

Figure 11: *Settings option*

In the settings menu, under the main menu settings option, the unit of the magnetic field, the measurement range, time window duration to acquire values within, and brightness slider can be changed.

- Units that can be selected are: Millitesla / Tesla / Gauss
- Following measurement ranges can be selected: 60 mT / 500 mT / 4 T
- Time Window duration sets the time over which the measured values are acquired and analysed during the measurement for determination of the Min, Max, RMS, and AVG values that are shown in the detailed view of each measured field component and Btotal. The time window can be set for 5s / 10s / 30s / 1min / 2min / 5min.
- Brightness slider adjusts the brightness of the display. Please note that this function has an impact on the battery discharge.

7.4 Measurement units

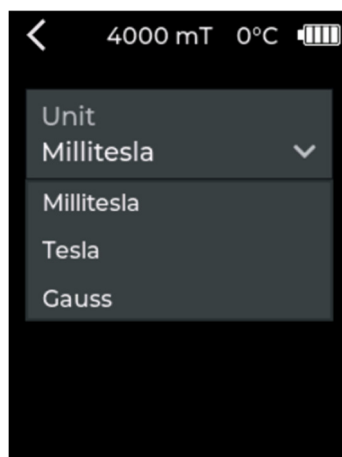

Figure 12: *Unit change settings*

The SENIS 3MH1-E Handheld Teslameter allows the following units, each with different effects on the values with range settings:

- Gauss [G]
- Millitesla [mT]
- Tesla [T]

7.5 Measurement ranges

The measurement ranges are selectable from the drop-down menu. In case of measuring a stronger magnetic field with lower range, the device will indicate that the selected measurement range is exceeded.

Please note, it is safe to measure a stronger magnetic field with a lower range; this will not damage the sensor.

NOTE : For 4 T range, the calibration was executed at 2 T, and subsequent data extrapolation was applied. It's important to note that the measurement accuracy for the 4 T range may vary compared to measurements up to 2 T.

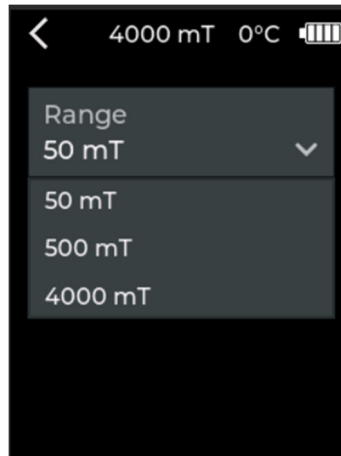

Figure 13: *Range settings*

7.6 Sample Rate

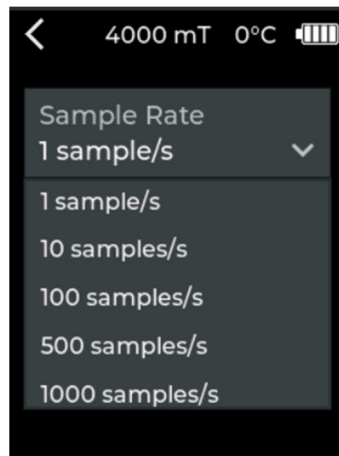

Figure 14: *Sample Rate settings*

Sample Rate defines how many samples are acquired in time and presented/updated on device screen.

7.7 Statistic Time

Changing the time window duration affects the magnetic field measurement's minimum, maximum, average, and RMS values. During a specified time window, the device collects the data.

If a new minimum or maximum value is detected, this triggers the start of a new time window.

However, if no new minimum or maximum value is found during the defined time window, the measured values are displayed for the specified time duration.

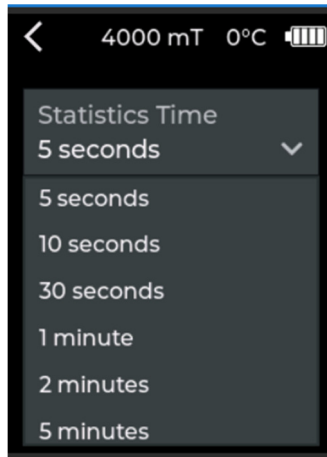

Figure 15: *Statistic Time settings*

7.8 About page

The "About" page on the device displays important information such as the firmware version and date, calibration date, and sensor ID (that is the Teslameter serial number).

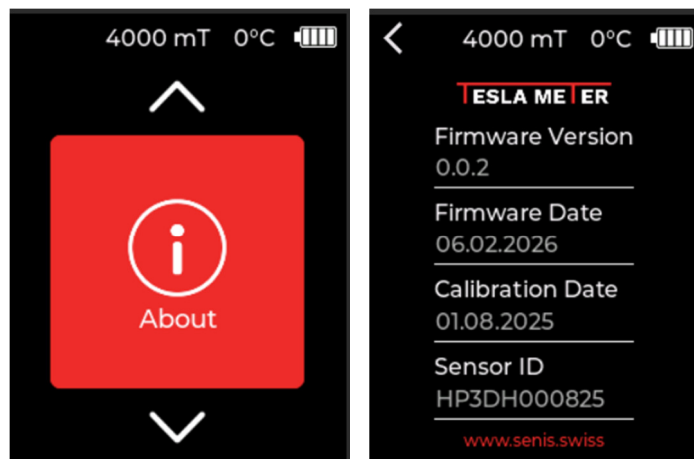

Figure 16: *About page option*

7.9 Record data in file

To record data, users can press the red circle recording button located in the bottom right corner of the live table window. Once recording has begun, the button changes to a red square icon, indicating that the recording is in progress. A pop-up message will inform user that recording has started. The timer in the bottom part of display will show the recording time in hours, minutes and seconds.

To stop recording, users need to press the stop recording button, which the same red square, and located in the same position at the bottom right corner of the screen. A pop-up message will inform user that recording has stopped.

Once the recording has stopped, the button returns to its original red circle icon.

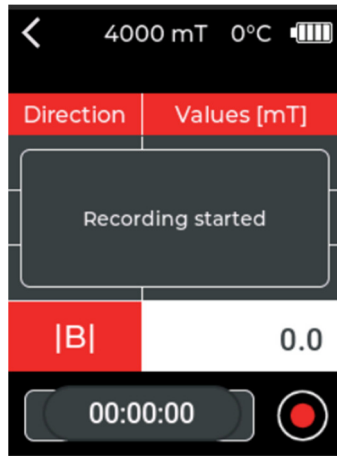

Figure 17: Recording in progress

The recorded data is saved as a CSV file on the device SD card and can be downloaded on a PC by removing card from device and inserting it in the PC.

The recorded data files are in CSV format and are named in the SD card starting with 'R' followed by counter starting from 00001.

If no data have been saved, the list will be empty.

The recorded data has following format:

TimeStam	Bx[mT]	BxAvg[mT]	BxMax[mT]	BxMin[mT]	BxRMS[mT]	By[mT]	ByAvg[mT]	ByMax[mT]	ByMin[mT]	ByRMS[mT]	Bz[mT]	BzAvg[mT]	BzMax[mT]	BzMin[mT]	BzRMS[mT]	Btot[mT]	BtotAvg[mT]	BtotMax[mT]	BtotMin[mT]	BtotRMS[mT]	Temp[C]
49854	0.2	0.3	3.2	-1.9	1.6	-5.2	-5.1	-2.2	-7.7	5.3	3.9	4	6.6	1.5	4.3	6.5	7	8.1	6.3	7	23.9
49954	0	0.3	3.2	-1.9	1.6	-5.2	-5.1	-2.2	-7.7	5.3	4.1	4	6.6	1.5	4.3	6.6	7	8.1	6.3	7	23.9
50054	-0.1	0.3	3.2	-1.9	1.6	-4.9	-5.1	-2.2	-7.7	5.3	4.1	4	6.6	1.5	4.3	6.4	7	8.1	6.3	7	23.9
50154	0	0.3	3.2	-1.9	1.6	-4.9	-5.1	-2.2	-7.7	5.3	4.4	4	6.6	1.5	4.3	6.6	7	8.1	6.3	7	23.9

Figure 18: CSV data

The data recorded by the SENIS 3MH1-E Handheld Teslameter follows a specific format, where each column represents a different element of the magnetic field being measured.

The table below (Table 5.1) shows the names of the columns and the corresponding magnetic field components.

Tab.5.1. Columns in CSV file

A: Time Stamp				
B: B _x	C: B _x Avg	D: B _x Max	E: B _x Min	F: B _x RMS
G: B _y	H: B _y Avg	I: B _y Max	J: B _y Min	K: B _y RMS
L: B _z	M: B _z Avg	N: B _z Max	O: B _z Min	P: B _z RMS
R: B	H: B Avg	S: B Max	T: B Min	U: B RMS
V: Temperature				

Description:

- **Time Stamp:** sample collection time in ms
- **B_x:** X-component of the measured magnetic field
- **B_y:** Y-component of the measured magnetic field
- **B_z:** Z-component of the measured magnetic field
- **B:** total measured magnetic field strength
- **Avg:** Average value of the magnetic field component within the selected time window
- **Max:** Maximum value of the magnetic field component within the selected time window
- **Min:** Minimum value of the magnetic field component within the selected time window
- **RMS:** Root mean square of the magnetic field component within the selected time window
- **Temperature:** Calibrated temperature of the magnetic sensor chip

8. 3MH1-Probe:

The probe incorporates the SENISENS 3DHALL chip (SEN3DHx) and it is calibrated by saving the calibration data in the chip's internal registers. Each probe has serial number and can be ordered separately (the full probe interchangeability is provided). The probe is fully non-magnetic, so it can be used, when connected to the extension cable, in vicinity of strong magnetic field sources.

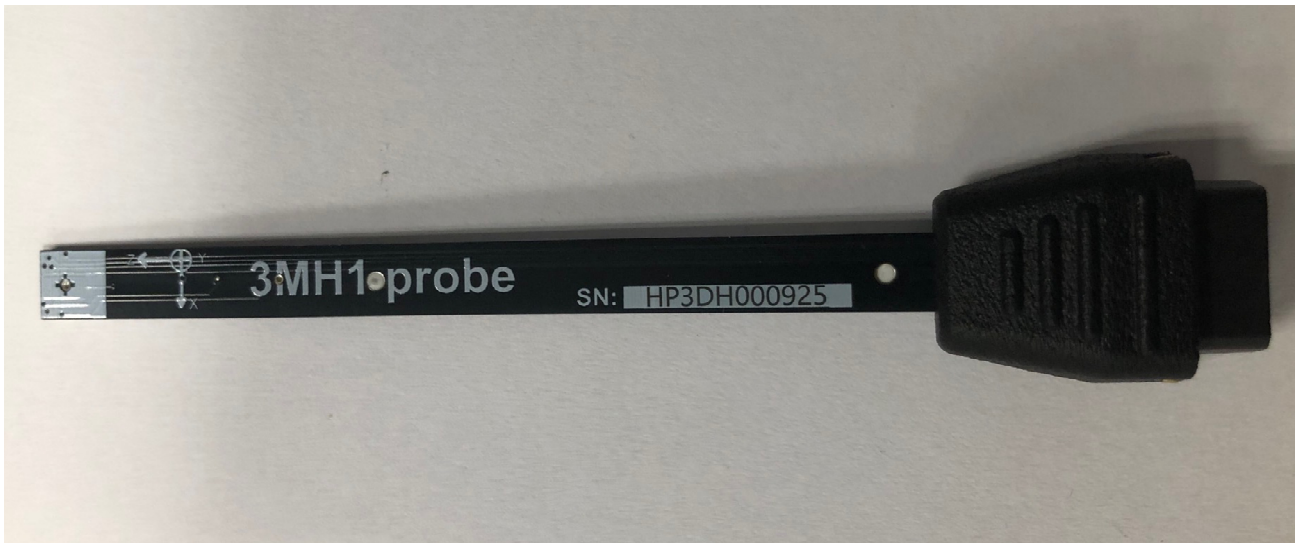

Figure 19: 3MH1-Probe

9. 3MH1-Cable:

The probe can be connected to the device by directly inserting probe into device or by using the delivered extension cable.

The cable, 3MH1-C has integrated electronics, which drives digital signals into connectors, allowing for the cable lengths of 10 meters or even more, depending on the specific application and signalling rate.

The Male part of cable can be fixed with two screws on the suitable holder, so that together with the probe it is possible to mechanically fix it in the customer's measurement setup.



Figure 20: *3MH1-Cable*