

Datasheet: SENIS 3MH1-E Teslameter

3-axis portable SENIS Handheld Teslameter

DESCRIPTION:

SENIS Handheld Teslameter is an easy-to-use portable teslameter which allows users to measure all 3 components of the magnetic field.

It simultaneously measures the magnetic field with a direct view of the magnetic field strength on the integrated touchscreen.

With user-friendly software unit of the measured magnetic field, gain, and measurement averaging time window can be changed.

Build-in software allows user to download recorded data in CSV file via serial interface.

It is powered from the internal battery, and it does not require to be powered by an external power supply.

Due to unique features of the applied fully integrated 3-axis Hall probe, all three components of the magnetic field (B_x , B_y , B_z) are measured simultaneously at virtually same point. It allows users to perform a fast, high-resolution measurement of magnetic flux density of the magnetic fields. The measured values are presented on the device touch-display. The magnetic field sensitive area of the applied Hall probes is within a $100\ \mu\text{m} \times 100\ \mu\text{m}$ square, which allows measurements of homogeneous and highly inhomogeneous magnetic fields.

New dual-usage of the device will be allowed due to the dedicated extension cable, which allows users to unscrew the probe with a holder from the handheld unit and to connect it via the extension cable. This enables flexible usage of the probe in hard-to-reach or spatially constrained environments, effectively turning the device into a handheld teslameter with a remote probe on cable for increased accessibility and versatility in challenging measurement setups.



Figure 1: SENIS 3MH1-E Handheld Teslameter with and without extension cable

KEY FEATURES:

- Fast, accurate view of magnetic field strength
- Portable device without the need for an external power supply
- Build-in touch screen to operate the Teslameter
- Exchangeable probe
- Measures all three 3 field components of a magnetic field (Bx, By, Bz)
- Very high magnetic resolution small sensitive volume of 100µm x 100µm x 10µm
- Dedicated cable for increasing the accessibility of the probe
- Probe holder and the probe are fully non-magnetic
- Transit case is included
- Zero Gauss Chamber can be optionally delivered

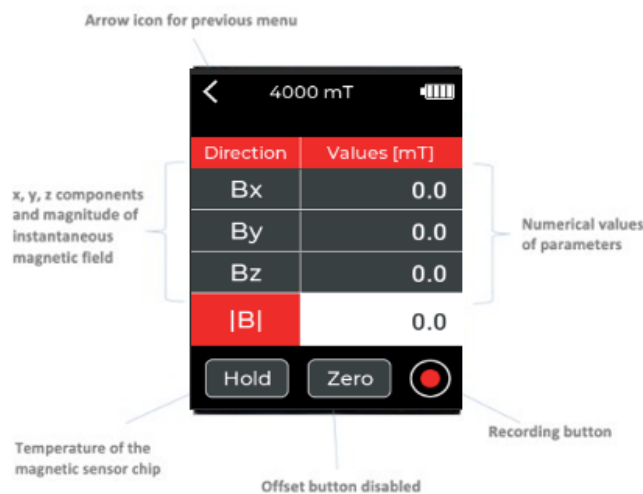

Figure 2: SENIS 3MH1-E Handheld Teslameter measurement tab with Bx, By, Bz and Btotal



Figure 3: SENIS 3MH1-E Handheld Probe and the extension cable

TYPICAL APPLICATIONS:

- Quality control and monitoring of permanent magnets and systems
- Measurements in hard-to-reach places
- Measurement of the environmental magnetic fields
- Development of magnet systems & process control
- Application in laboratories and in production lines

SPECIFICATIONS:

Magnetic measuring properties	
Measurement Ranges / Full Scale (FS)	$\pm 50\text{mT}$ / $\pm 500\text{mT}$ / $\pm 4\text{T}$ (extrapolated from measured data up to $\pm 2\text{T}$)
Measurement Volume	$100\mu\text{m} \times 100\mu\text{m} \times 10\mu\text{m}$
Standard cable length	1m (other options: 2m / 5m / 10m – ask your SENIS representative)
Accuracy of measurement	2% of FS for each component
Offset at B=0 mT	>0.2% of FS
Resolution at Sample Rate 10S/s and 1s averaging, standard deviation.	at 50mT range - $50\mu\text{T}$
	at 500mT range - $80 \div 180\mu\text{T}$
	at 4T range - $0.8 \div 1.2\text{mT}$
Calibrated temperature range	$20^\circ - 30^\circ\text{C}$
Software and Communication	
Power Supply	USB-C, 5V, 0.5A, rechargeable Li-ion battery
Touch screen	Capacitive LCD with backlight for good visibility
Interface	USB 3.0
File format for data exchange	.csv
Operation Options	
Setting Zero, Streaming acquisition, Hold Function	
Battery Status Display	
Displayed units: Gauss / mT / T	
Mechanical	
Housing	Rugged, lightweight
Total weight	160g
Operation temperature range	$10^\circ\text{C} - 50^\circ\text{C}$

DIMENSIONS:

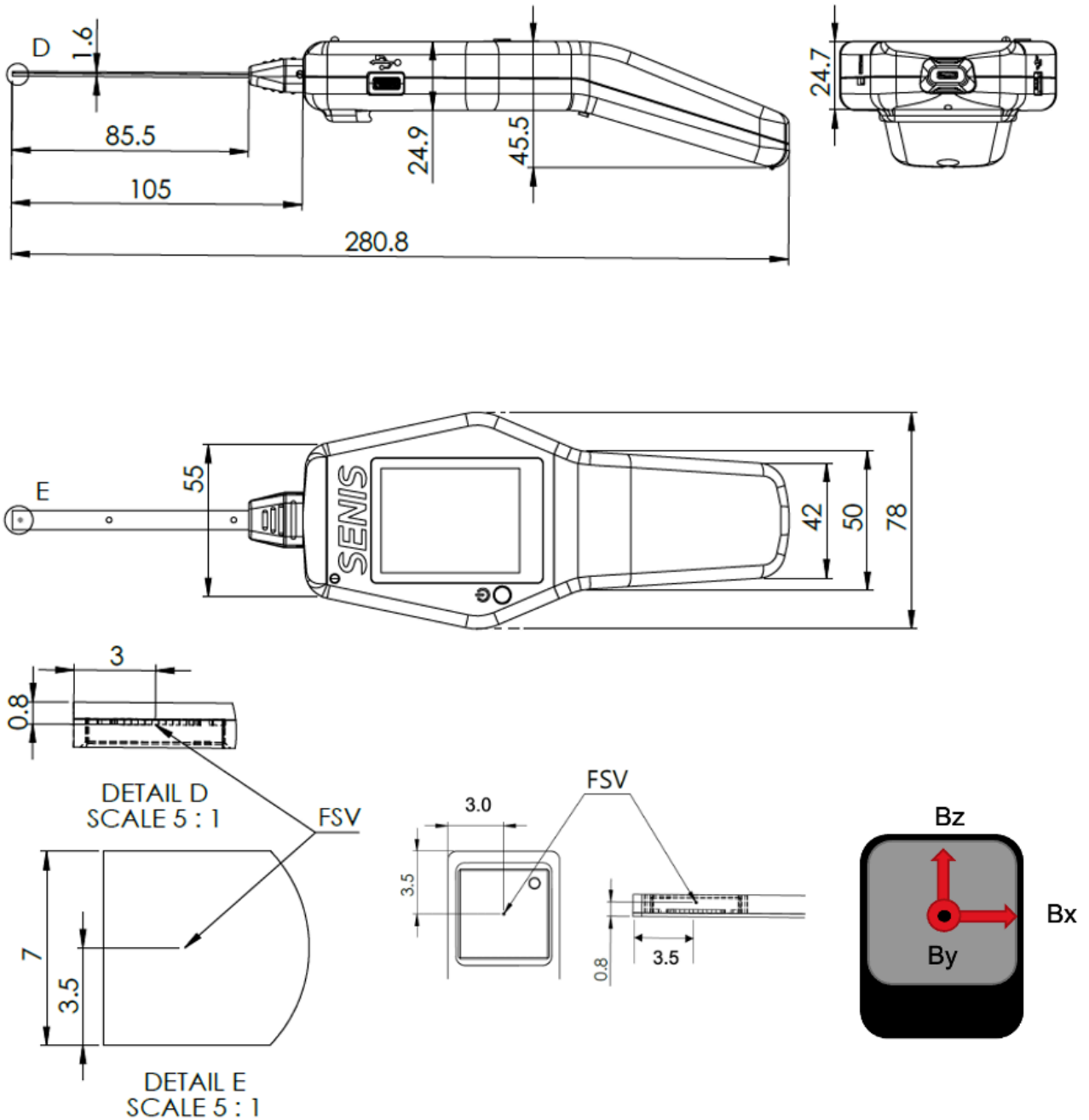

Figure 4: Structure and dimensions of the 3MH1-E Handheld Teslameter and position of the FSV.