

Datasheet: SENIS 3MH1 Teslameter

3-axis portable SENIS Handheld Teslameter

DESCRIPTION:

SENIS Handheld Teslameter is an easy-to-use portable teslameter which allows users to measure all 3 components of the magnetic field.

It simultaneously measures the magnetic field with a direct view of the magnetic field strength on the integrated touchscreen.

With user-friendly software unit of the measured magnetic field, gain, and measurement averaging time window can be changed.

Build-in software allows user to download recorded data in CSV file via web interface.

It is powered from the internal battery, and it does not require to be powered by an external power supply.

Due to unique features of the applied fully integrated 3-axis Hall probe, all three components of the magnetic field (B_x , B_y , B_z) are measured simultaneously at virtually same point. It allows users to perform a fast, high-resolution measurement of magnetic flux density of the magnetic fields. The measured values are presented on the device touch-display. The magnetic field sensitive area of the applied Hall probes is within a $100\ \mu\text{m} \times 100\ \mu\text{m}$ square, which allows measurements of homogeneous and highly inhomogeneous magnetic fields.



Figure 1: SENIS 3MH1 Handheld Teslameter

KEY FEATURES:

- Fast, accurate view of magnetic field strength
- Portable device without the need for an external power supply
- Build-in touch screen to operate the teslameter
- Measures all three 3 field components of a magnetic field (Bx, By, Bz)
- Very high magnetic resolution
- Small sensitive volume of 100µm x 100µm x 10µm

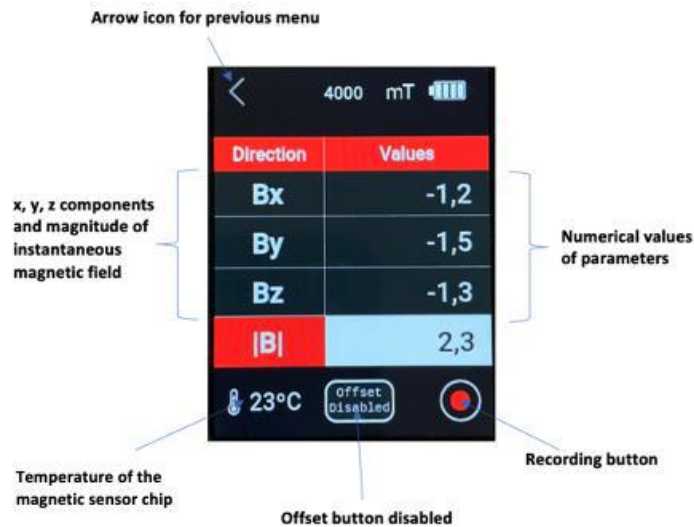

Figure 2: SENIS 3MH1 Handheld Teslameter measurement tab with Bx, By, Bz and Btotal



Figure 3: SENIS 3MH1 Handheld Teslameter without the nose cover

TYPICAL APPLICATIONS:

- Quality control and monitoring of permanent magnets and systems
- Measurements in hard-to-reach places
- Measurement of the environmental magnetic fields
- Development of magnet systems & process control
- Application in laboratories and in production lines

SPECIFICATIONS:

Magnetic measuring properties												
Measurement ranges	±60mT / ±500mT / ±4T (extrapolated from measured data up to ±2T)											
Measurement Volume	100µm x 100µm x 10µm											
Accuracy of measurement	2% of full scale for each component											
	4% of full scale for B, field amplitude. +/-20 uT at 0.5 mT (5G)											
Digital resolution	11bit											
Btotal Resolution at 10s averaging	at 60mT range - 55µT											
	at 500mT range - 160µT											
	at 4T range - 2mT											
Noise level (peak to peak, 6σ)	60mT range				500mT range				4T range			
	Bx	By	Bz	Btot	Bx	By	Bz	Btot	Bx	By	Bz	Btot
No averaging	400 µT	300 µT	350 µT	610µT	1.35mT	0.8mT	0.95mT	1.85mT	17mT	11.5mT	12.5mT	24mT
5s averaging	75 µT	60 µT	55 µT	110µT	155 µT	155 µT	210 µT	305µT	2mT	2mT	2.2mT	3.6mT
10s averaging	40 µT	26 µT	25 µT	55µT	77 µT	77 µT	111 µT	155µT	0.9mT	1.1mT	1.1mT	1.8mT
Frequency Range	0-2kHz											
Calibrated temperature range	20° - 30°C											
Software and Communication												
Power Supply	External, 5V, 1A, rechargeable NiMH battery											
Touch screen	Capacitive LCD with backlight for good visibility											
Interface	USB 3.0											
File format for data exchange	.csv											
Operation Options												
Setting Zero												
Start/Stop streaming acquisition												
Hold Function												
True RMS												
Battery Status Display												
Displayed units: Gauss / mT / T												
Mechanical												
Housing	Rugged, lightweight											
Total weight	160g											
Operation temperature range	10°C - 50°C											

DIMENSIONS:

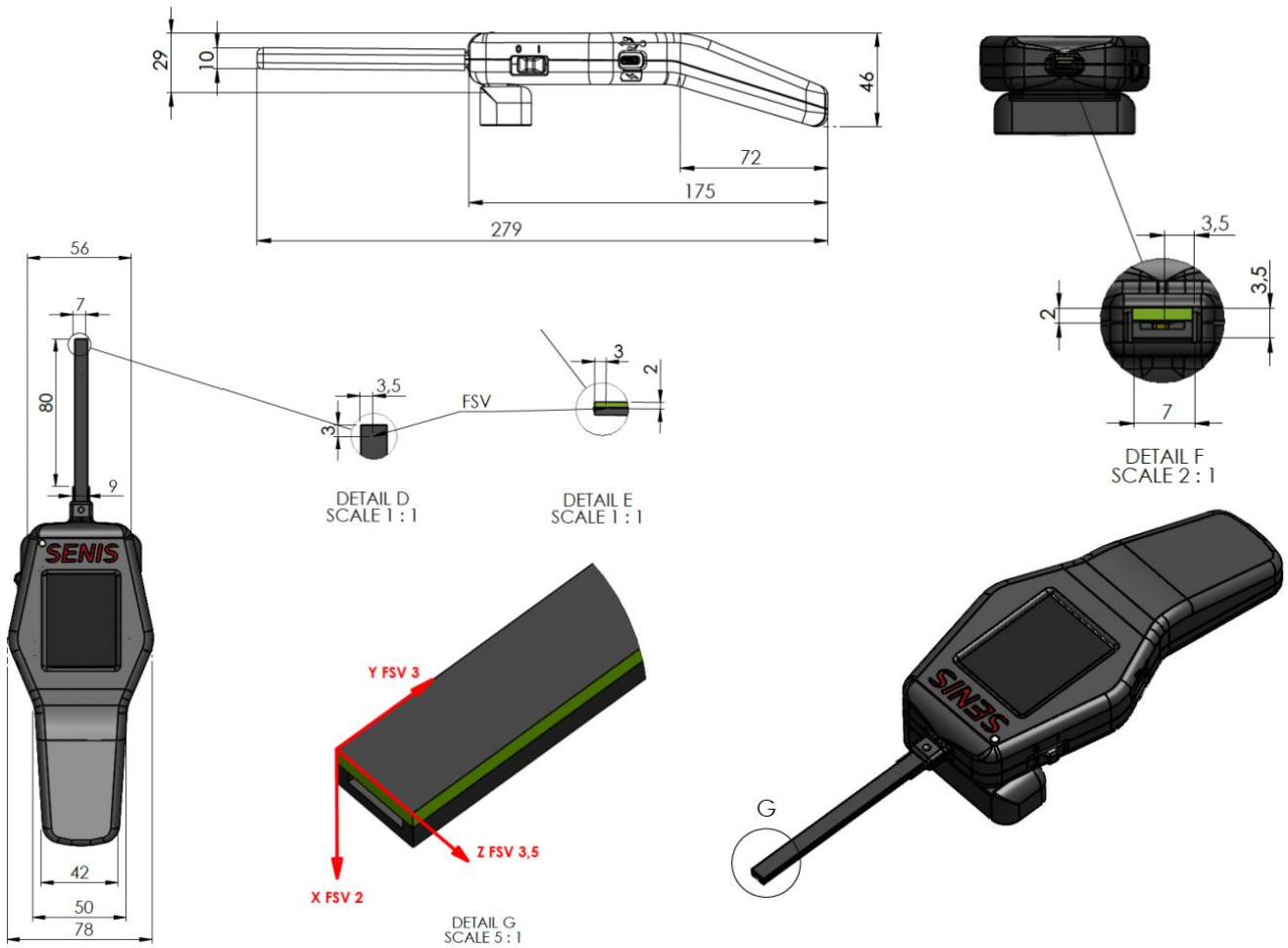

Figure 4: Structure and dimensions of the 3MH1 Handheld Teslameter and position of the FSV.